



# YOSHIMURA

RESEARCH & DEVELOPMENT OF AMERICA, INC.

5420 DANIELS STREET STE A, CHINO CA., 91786 · (800)634-9166 · (909)628-4722 · FACSIMILE (909)591-2198

[www.yoshimura-rd.com](http://www.yoshimura-rd.com)

## **RS-3 PERFORMANCE EXHAUST SYSTEM**

**SUZUKI**  
**2004-2010**  
**SV650**

**111225 (2,5,7)**

STAINLESS STEEL RACE ONLY SLIP-ON SYSTEM



**THIS PRODUCT IS DESIGNED FOR USE IN CLOSED COURSE RACING AND IS NOT INTENDED FOR HIGHWAY USE.**



**IMPORTANT NOTE:** Installation of this Yoshimura Exhaust System requires a permanent modification to your stock exhaust system. Ensure you read and familiarize yourself thoroughly with these instructions prior to installation.

NOTE: IN THE STATE OF CALIFORNIA, IT IS ILLEGAL TO MODIFY THE EMISSION CONTROL SYSTEM. WHICH INCLUDES THE FUEL INJECTION OF ANY VEHICLE.

**Caution:** Exhaust system can be extremely hot. Let motorcycle cool down before beginning installation.

**Note:** Read through all instructions before beginning installation.

### Tools Needed:

12mm socket, 11mm (or 7/16") sockets  
3/8" ratchet and extension  
11mm, 12mm wrench  
6mm Allen wrench  
Torque wrench  
Hack saw or cutting tool  
Drill with 3/16" drill bit  
Safety glasses

### Installation Steps:

- 1 Remove stock front header (unbolt exhaust flange and loosen exhaust clamp where stock front and rear header connect. See Fig.1 for fastener locations.)
- 2 Remove stock muffler with rear header. (Loosen exhaust clamp on rear stock header tube. Unbolt chassis and muffler mounts. See Fig's 2 & 3)
- 3 Replace old exhaust port gasket on front cylinder with new exhaust port gasket. (not supplied - Suzuki part no. 14181-22D01)
- 4 Use cutting tool to cut muffler 2 1/4" from the weld (See Fig's 4 & 5). After muffler has been cut bevel or sand smooth any sharp edges on pipe.
- 5 Re-install modified stock exhaust system in reverse order of steps 1 through 3. Torque chassis mount bolts to 2.5 kg-m (18 lb-ft).
- 6 Install supplied collector clamp over Slip-on mid-pipe with bolt to the inside and facing down. Install slip-on over cut portion of stock system. Ensure mid-pipe is fully seated on stock pipe. (See Fig. 7) Do not tighten clamp.
- 7 Apply heat insulator to inside of muffler clamp and slide clamp onto muffler. (Note direction of clamp in Fig. 6)

NOTE:



Fig. 1

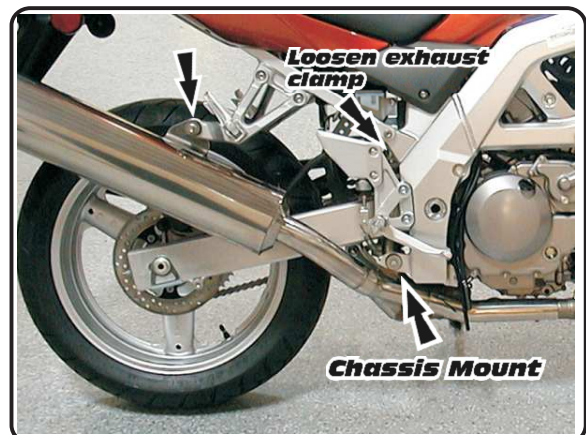

Fig. 2

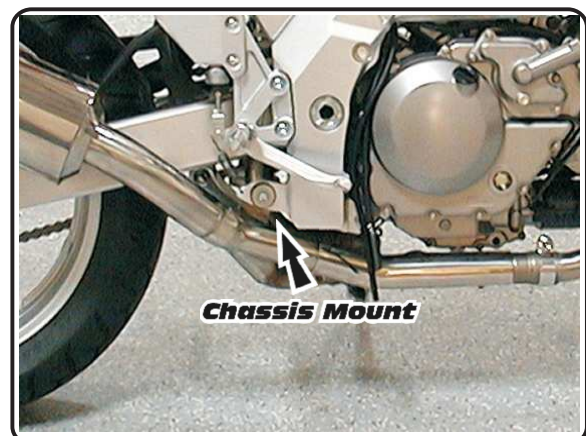

Fig. 3

- 8 Mount muffler clamp to outside of stock muffler bracket using stock bolt, washers and nut. (See Fig. 6) Torque bolt to 2.5 kg-m (18 lb-ft).
  - 9 Drill 3/16" hole in stock header and in the center of the hole on the mid-pipe (See Fig 7). Install supplied collector rivet so the head of the rivet is flush on the mid-pipe. Center collector clamp over rivet and torque clamp nut to 2.0 kg-m (14.5 lb-ft).
  - 10 It is recommended that the entire exhaust system be wiped down with rubbing alcohol to remove oil and fingerprints. This will help prevent tarnishing of the finish after the exhaust is heated up.
  - 11 Check for proper clearance between new exhaust system and motorcycle. (i.e. radiator, oil pan, swing-arm, etc.) If any problem is found, please carefully follow through the installation steps again. If problem still persists, please call the Yoshimura technical department at (800)634-9166, in CA (909)628-4722
- NOTE:** After starting motorcycle, it is normal for new exhaust system and muffler to emit smoke until oil residue burns off.



Fig. 4

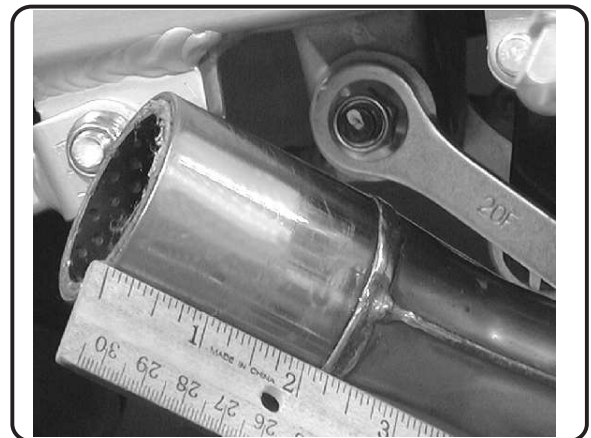

Fig. 5

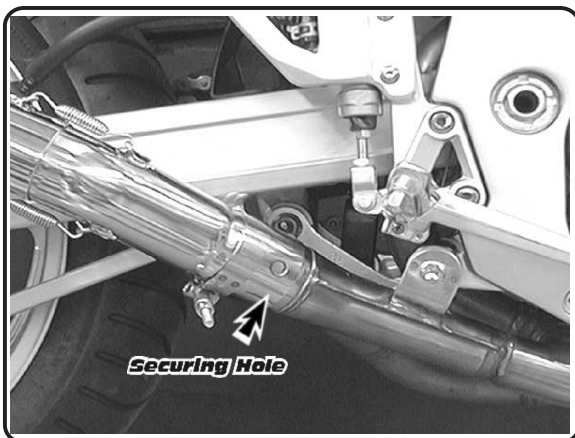

Fig. 7

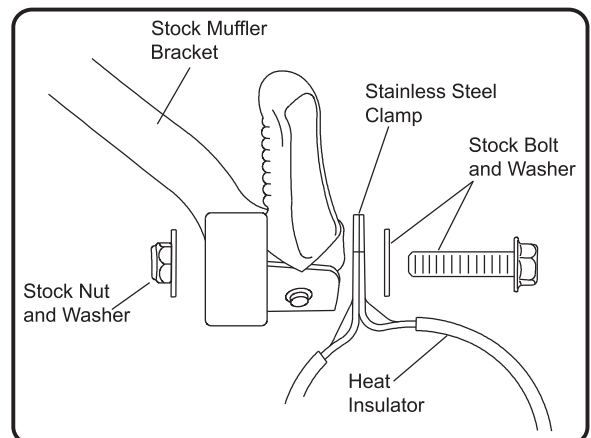
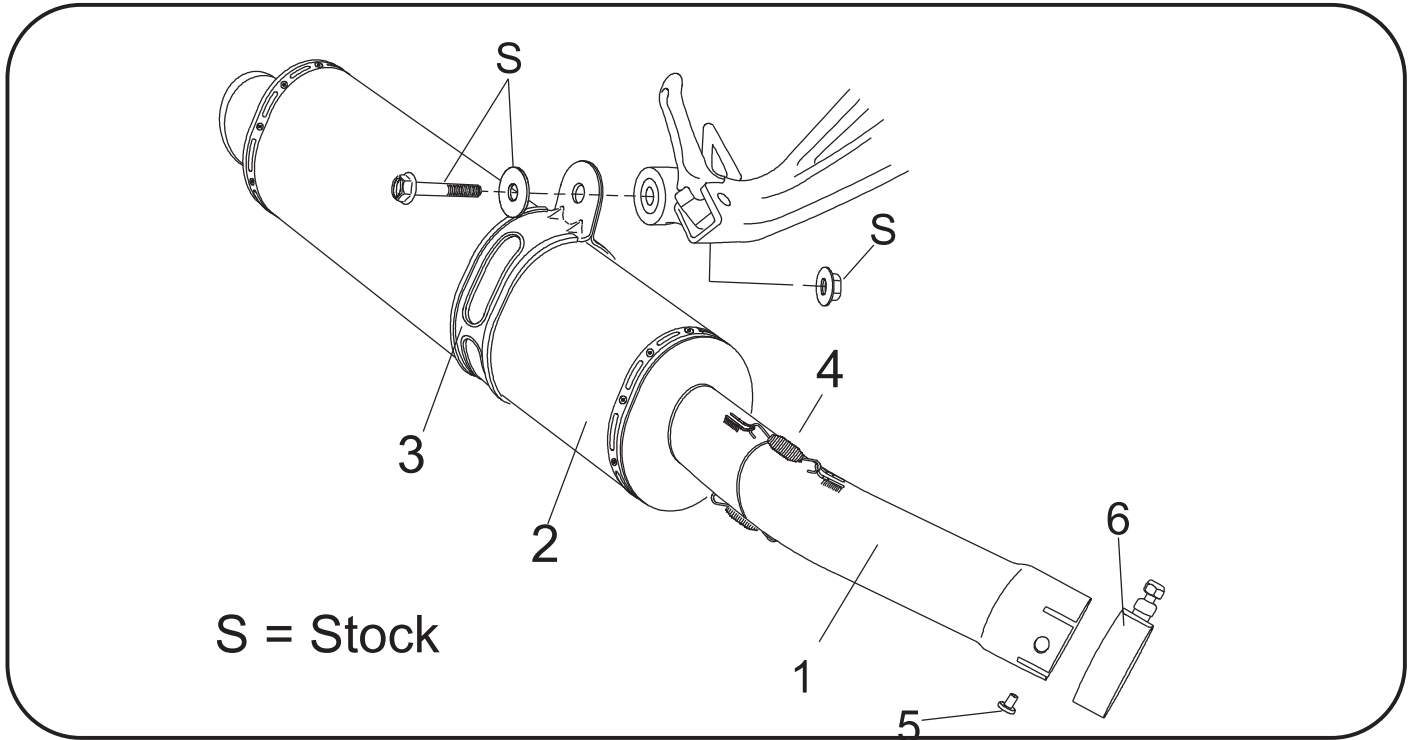

Fig. 6



**P/N 111225 (2,5,7)**



Parts Diagram

1	Yoshimura Tailpipe Stainless Steel Race	1	1112-235
2	RS-3 Oval Muffer Assembly	1	**
3	Muffer Clamp Stainless Steel or Titanium Sleeve uses Carbon Fiber Sleeve uses	1	COS450S8ASX COS450S8AS
4	2.5" Exhaust Spring	2	RACE-SPS
5	Securing Rivet	1	S-RIVET
6	2.5" Exhaust Clamp	1	20067
**	Muffer Clamp Heat Insulator	1	HT SHLDTRS
**	Yoshimura Vinyl Sticker	1	17029