



# YOSHIMURA

RESEARCH & DEVELOPMENT OF AMERICA, INC.

5420 DANIELS STREET STE A, CHINO CA 91710 · (800) 634-9166 · (909) 628-4722 · FAX (909) 591-2198

[WWW.YOSHIMURA-RD.COM](http://WWW.YOSHIMURA-RD.COM)

## *Signature Series*

Qualified Manufacturer Declared "Replacement Part"

**2010~2018**  
**SUZUKI RM-Z250**  
**218312D320 (AL/SS)**  
**RS-4 Stainless Steel Slip-On**

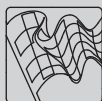

Signature Series systems are:

- CARB/EPA tail-pipe emissions compliant.
- Marked with appropriate EPA noise labels.
- Independent laboratory tested for EPA new vehicle noise compliance.

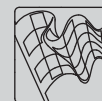

CAUTION: The muffler packing on this system **MUST** be replaced every 6-8 hours of use, or every 1-2 motos. Failure to follow recommended muffler re-packing interval can cause muffler damage and may void the warranty.



NOTE: IN THE STATE OF CALIFORNIA, IT IS ILLEGAL TO MODIFY THE EMISSION CONTROL SYSTEM, WHICH INCLUDES THE FUEL INJECTION OF ANY VEHICLE.

**Caution:** Exhaust system may be extremely hot. Let motorcycle cool down before beginning installation.

**Note:** Read through all instructions before beginning installation.

## Tools Needed:

Metric Socket Set  
Ratchet Wrench and Extension  
Torque Wrench  
Spring Puller Tool

## Installation Steps:

### 1 Stock Exhaust Removal

- a. Remove right rear number plate (see Fig. 1 for fastener locations).
- b. Loosen stock muffler clamp.
- c. Unbolt chassis and muffler mount bolts.
- d. Remove stock muffler (see Fig. 2 for fastener locations).

### 2 Install Yoshimura Exhaust

- a. Slide supplied tailpipe clamp over stock header pipe.
- b. Temporarily remove tailpipe-to-muffler spring.
- c. Install supplied rubber grommet into aluminum muffler mounting bracket. Install aluminum insert into rubber grommet (make sure shoulder of aluminum insert faces toward the frame, see Fig. 3).
- d. Install Yoshimura tailpipe and muffler onto stock header.  
*Note:* Stock tailpipe gasket will not be reused.
- e. Mount stock chassis mount bolt to tailpipe. Leave loose.
- f. Mount muffler with stock muffler mount bolt and washer. Leave loose.
- g. Install supplied tailpipe-to-muffler spring.
- h. Check exhaust for proper position and clearance and adjust if necessary.
- i. Tighten chassis mount and muffler mount bolts to 15 ft-lb ( 21 N-m ).
- j. Tighten tailpipe clamp to 15 ft-lb ( 21 N-m ).

### 3 Reinstall

- a. Reinstall number plate.
- b. It is recommended that the muffler and tailpipe be wiped down with rubbing alcohol to remove oil and fingerprints. This will help prevent tarnishing of the finish after the exhaust is heated up.

Before starting motorcycle, check for proper clearance between new exhaust system and rear suspension (i.e. tire, swingarm, brake, rear shock, etc). If any problem is found, please carefully follow through the installation steps again. If problem still persists, please call Yoshimura tech department at (800) 634-9166 / in CA (909) 628-4722.

**NOTE:** After starting motorcycle, it is normal for new exhaust system and muffler to emit smoke until oil residue burns off.



Fig. 1

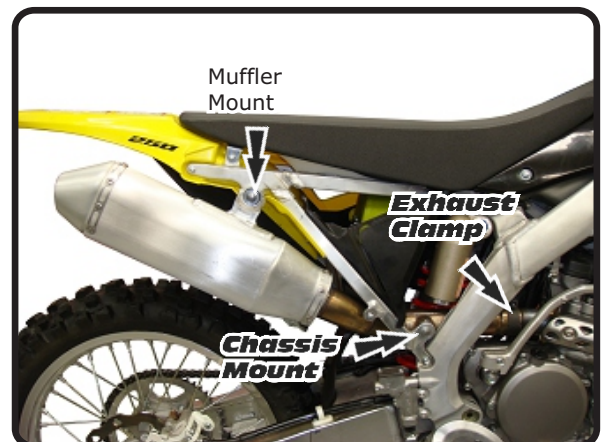

Fig. 2

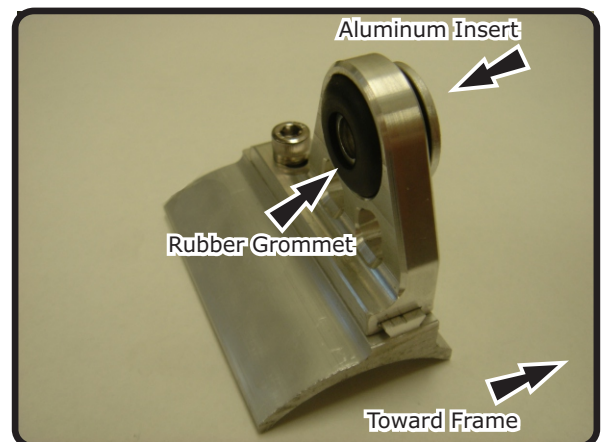
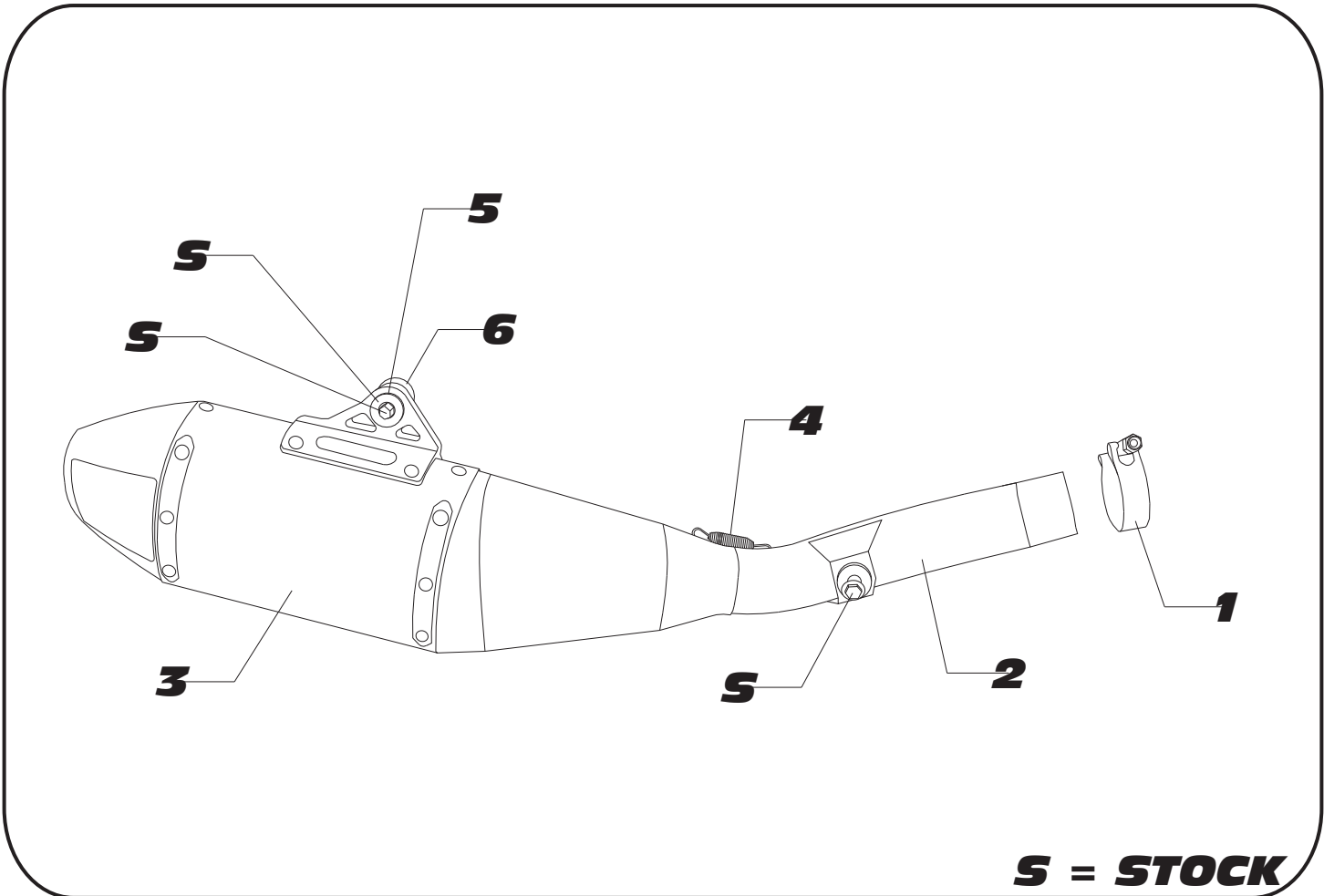

Fig. 4

**PN: 218312D320**



**S = STOCK**

Parts Diagram

NO.	DESCRIPTION	QTY	PART #
1	Stainless Steel Exhaust Clamp	1	22057
2	Yoshimura Tailpipe	1	2183-152-1
3	Yoshimura Race Muffler with Aluminum Sleeve	1	218312D320-RMA
4	Short Exhaust Spring	1	RACE-SPX-1
5	Muffler Mount Rubber Grommet	1	Z1022
6	Aluminum Insert	1	ALS-010
**	AMA 94dB Sound Insert (Installed)	1	INS-10-K
**	2m-MAX Sound Insert	1	INST-14-K
**	Instructions Manual	1	INST KIT
**	Spring Puller Tool	1	ST-200
**	Yoshimura Vinyl Sticker	1	17029
**	Muffler Wash Plug	1	347PLUG
<b>OPTIONAL REPLACEMENT PARTS</b>			
	Spark Arrestor		SA-08-K
	Re-pack Kit		REPACK-RS4-PK11



# YOSHIMURA

RESEARCH & DEVELOPMENT OF AMERICA, INC.

5420 DANIELS STREET SUITE A, CHINO, CA 91710 · (800)634-9166 · (909)628-4722 · FACSIMILE (909)591-2198

[www.yoshimura-rd.com](http://www.yoshimura-rd.com)

**INS-10-K | YOSHIMURA LOW VOLUME SOUND INSERT KIT**

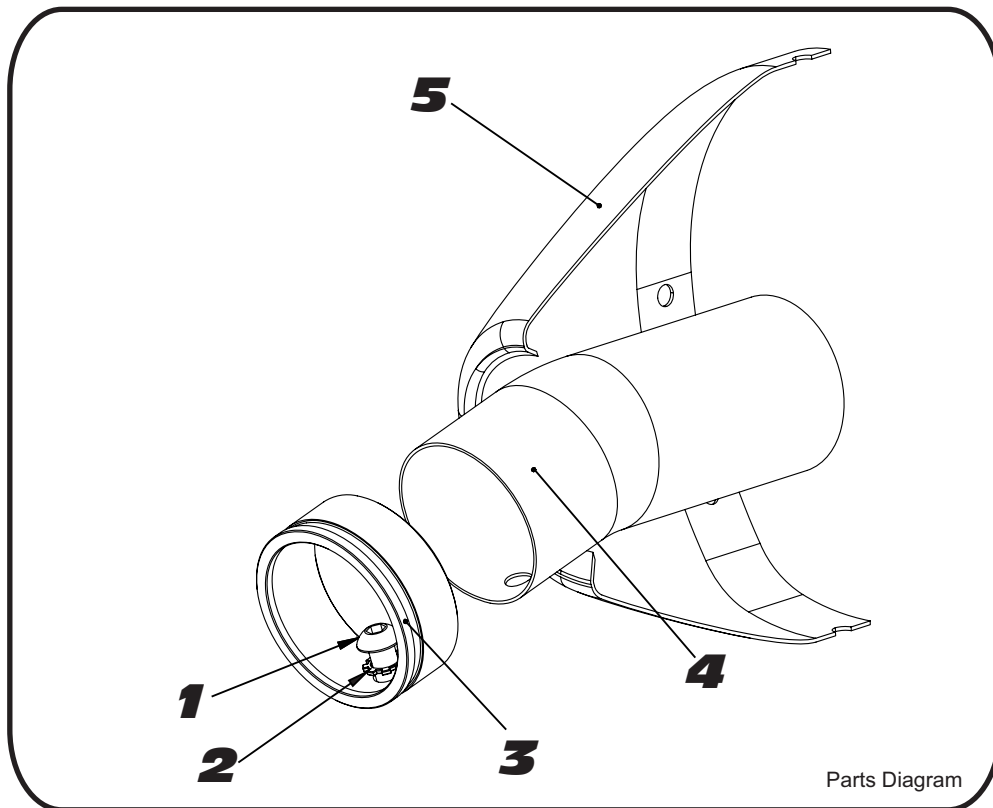

NO.	DESCRIPTION	QTY	PART #
1	6mm X 12mm Button Head Cap Screw	1	M6X12BHS
2	6mm Lock Washer	1	6MMLCKWTHR-TH
3	RS4 Aluminum Insert Ring	1	RS4-RING-1625
4	Low Volume Insert	1	INS-P
5	Yoshimura Exhaust	**	**

- 1 Using a 4mm Allen key, remove the bolt that secures the aluminum ring and sound insert to the muffler (see Parts Diagram for location).
- 2 Remove the sound insert from the muffler.
- 3 Inspect the sound insert for cracks or damage and replace if necessary.
- 4 Re-install sound insert and aluminum ring. Torque the sound insert securing bolt to 1.0 kg-m (7.3 lb-ft).  
**NOTE:** It is recommended that a low strength "Loc-tite" is used on the sound insert securing bolt.