

# Anbauhinweise Crash Ball Achsprotectoren Triumph Daytona/Street Triple 675 Art.-Nr.: 556T037..

**Zuerst die linke Seite montieren!**

## Anbau hinten links

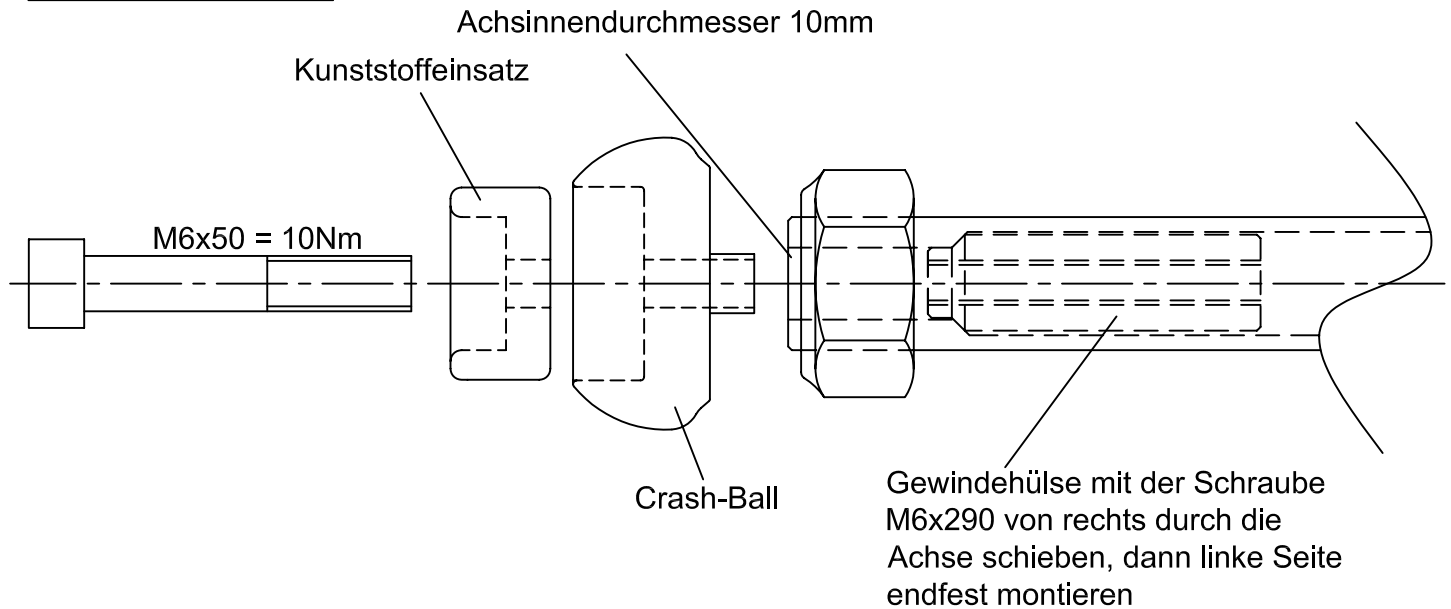

## Anbau hinten rechts

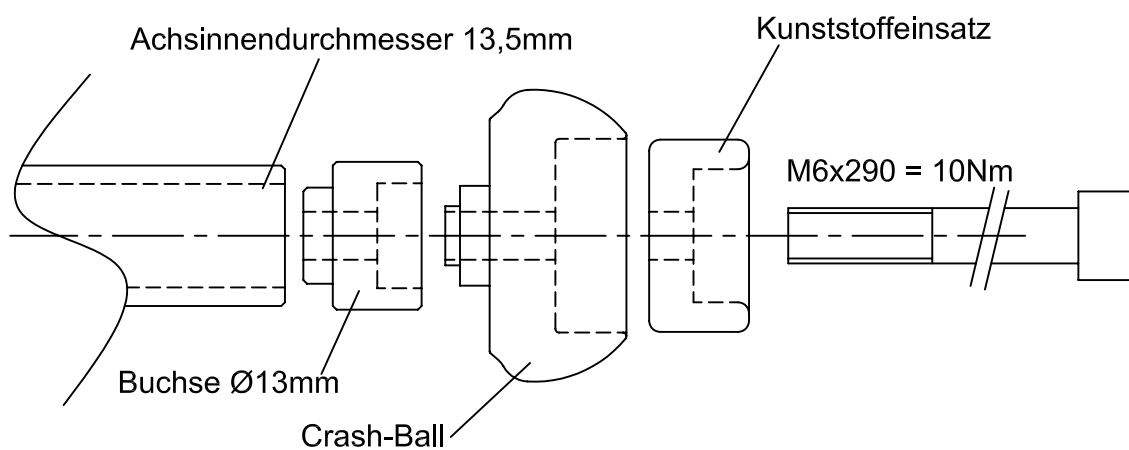

LSL-Motorradtechnik GmbH • D-47809 Krefeld

[www.lsl.eu](http://www.lsl.eu)

Stand: 09/2007

**Fitting instruction Crash Balls for axle protection**  
**Triumph Daytona/Street Triple 675**  
**part-no.: 556T037..**

**Mount the left side at first!**

**Fitting rear, left side**

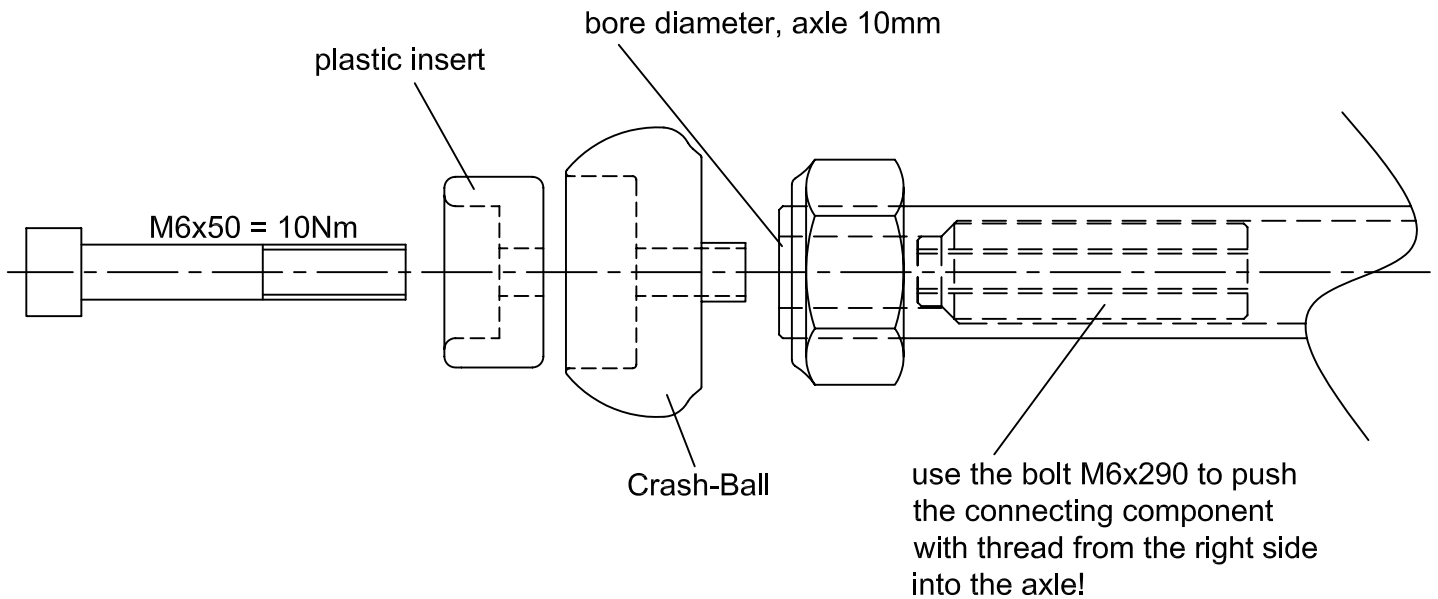

**Fitting rear, right side**

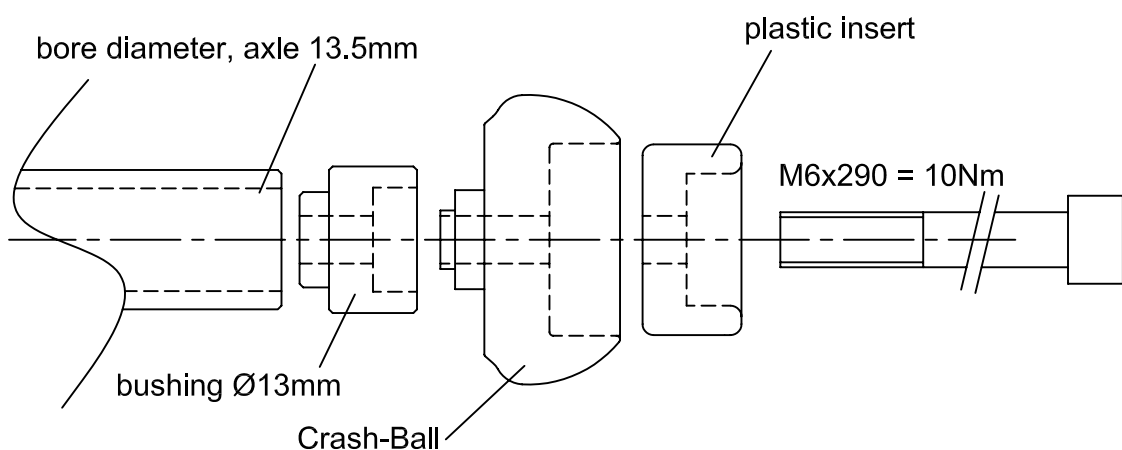

LSL-Motorradtechnik GmbH • D-47809 Krefeld

[www.lsl.eu](http://www.lsl.eu)

Stand: 11/2007

**Instructions de montage pour protecteurs d'axe Crash Ball**  
**Triumph Daytona/Street Triple 675**  
**N°article: 556T037..**

**Commencez par le montage du côté gauche!**

**Montage à l'arrière gauche**

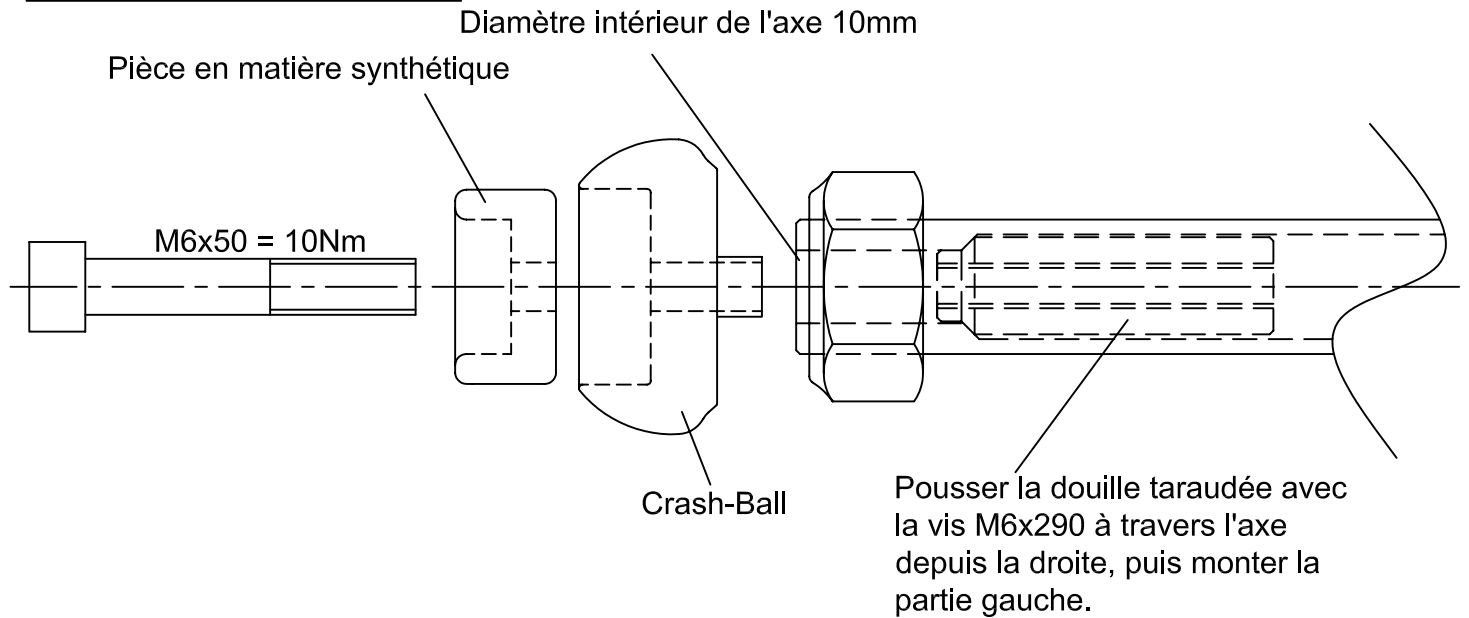

**Montage à l'arrière droit**

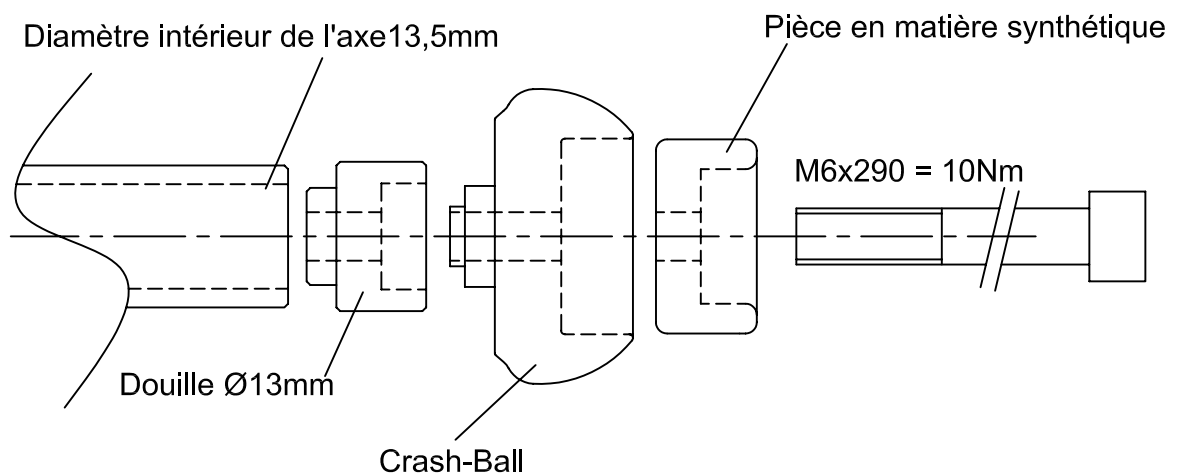

LSL-Motorradtechnik GmbH • D-47809 Krefeld

[www.lsl.eu](http://www.lsl.eu)

Stand: 18.03.2008