

HYPERPRO

LOWERING KIT / VERLAGINGSSET for HONDA CBR 1100 XX Models '97>

LK-HO11-002-30 PART LIST

LINK0058 - Lowering link/ verlagingslink	2
M10 Washer/ ring	3
-	-
-	-

ALL IDEAS, DESIGNS, ARRANGEMENTS AND PLANS INDICATED OR REPRESENTED BY THIS DRAWING ARE OWNED BY HYPERPRO AND WERE CREATED, EVOLVED AND DEVELOPED FOR USE ON AND IN CONNECTION WITH THE SPECIFIC PROJECT. NONE SUCH IDEAS, DESIGNS, ARRANGEMENTS OR PLANS SHALL BE USED BY OR DISCLOSED TO ANY PERSON, FIRM OR CORPORATION FOR ANY PURPOSE WHATSOEVER WITHOUT THE WRITTEN PERMISSION OF HYPERPRO.

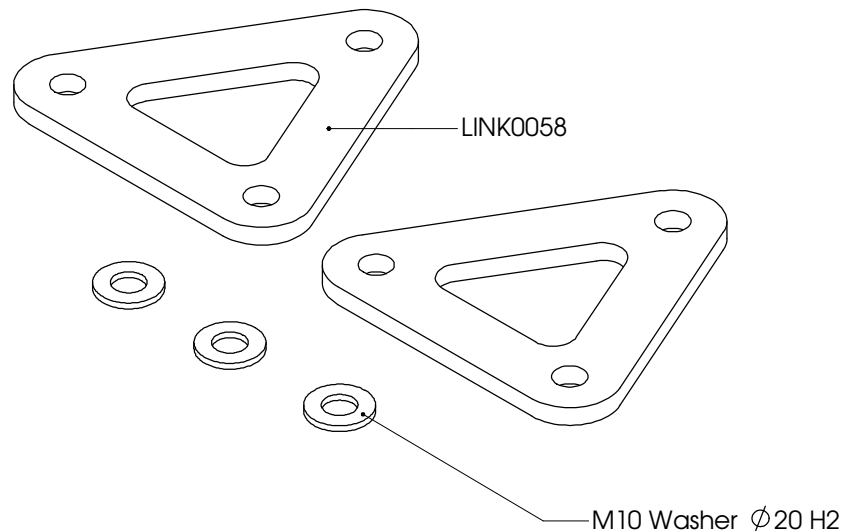

Inbouw handleiding

VOORZIJD

De vorkpoten maximaal 18 mm door de bovenste kroonplaat heen steken. De veervoorspanning minimaal zetten (tegen de klok in draaien). De remslangverdeler aan de onderkant van de vorkbrug zover naar boven buigen, dat er tussen de remslangen en remleidingen over het spatbord 10mm meer afstand ontstaat. De remslangen mogen niet te strak staan in uitgeveerde positie. De luchtkamer reduceren als de vork wil doorslaan.

ACHTERZIJD

De bestaande link vervangen door de HYPERPRO verlagingslink. Let op dat de pijl in de rijrichting staat. Het achterwiel eerst belasten voordat de link vastgezet wordt.

LET OP! DE LENGTE VAN DE ZIJSTANDAARD MOET 15-20mm INGEKORT WORDEN. AFTERMARKET SPATBORDEN KUNNEN NIET TOEGEPAST WORDEN.

Instruction manual

FRONT

Mount the fork legs max 18mm through the triple clamp. Turn the preload adjuster to minimum preload (counter clockwise). Bend the brake hose distributor on the underside of the forkbridge up, so there is 10mm extra space between the front mudguard between the brake hoses and brake lines. The brake hoses must not be too tight at full extension. Reduce the air chamber if the fork hits the end of its stroke.

REAR

Replace the original link by the HYPERPRO lowering link. Make sure that the arrows are pointing in the riding direction. Put some pressure on the rear wheel before tightening the link.

WARNING! SHORTEN THE SIDE-STAND 15-20mm. AFTERMARKET REAR MUDGUARDS CAN NO LONGER BE USED.

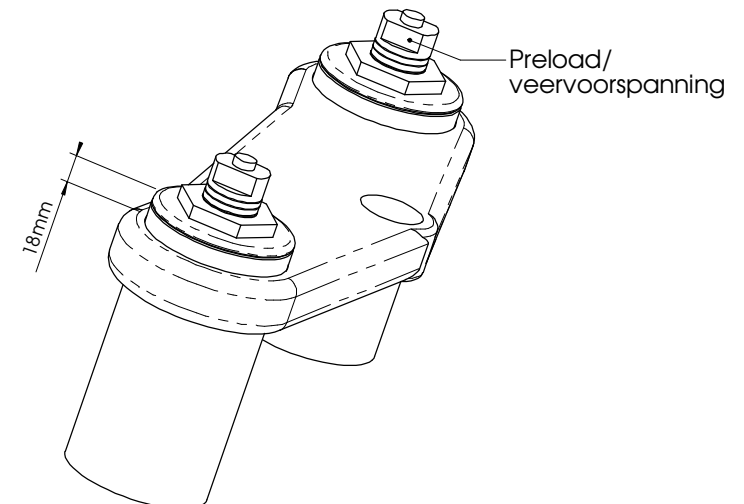

See WWW.HYPERPRO.COM for more info about our products.