

# HYPERPRO

## LOWERING KIT / VERLAGINGSSET for SUZUKI GSX 750 F Models '98>

### LK-SU07-004-45 PART LIST

PR141970 - Pull rod/ trekstang	2
-	-
-	-
-	-

ALL IDEAS, DESIGNS, ARRANGEMENTS AND PLANS INDICATED OR REPRESENTED BY THIS DRAWING ARE OWNED BY HYPERPRO AND WERE CREATED, EVOLVED AND DEVELOPED FOR USE ON AND IN CONNECTION WITH THE SPECIFIC PROJECT. NONE SUCH IDEAS, DESIGNS, ARRANGEMENTS OR PLANS SHALL BE USED BY OR DISCLOSED TO ANY PERSON, FIRM OR CORPORATION FOR ANY PURPOSE WHATSOEVER WITHOUT THE WRITTEN PERMISSION OF HYPERPRO.

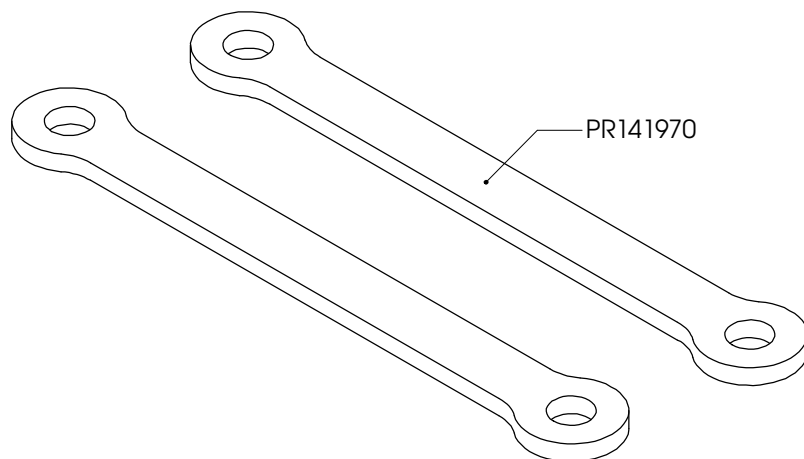

### Inbouw handleiding

#### VOORZIJDJE

De vorkpoten maximaal 10 mm door de bovenste kroonplaat heen steken. De veer-voorspanning minimaal zetten (tegen de klok in draaien). De luchtkamer reduceren als de vork wil doorslaan.

#### ACHTERZIJDJE

De bestaande link vervangen door de HYPERPRO verlagingslink. Het achterwiel eerst belasten voordat de link vastgezet word.

LET OP! DE LENGTE VAN DE ZIJSTANDAARD MOET 25-30mm INGEKORT WORDEN. AFTERMARKET ACHTERSPEATBORDEN KUNNEN NIET MEER WORDEN TOEGEPAST.

### Instruction manual

#### FRONT

Mount the fork legs max 10mm through the triple clamp. Turn the preload adjuster to minimum preload (counter clockwise). Reduce the air chamber if the fork hits the end of its stroke.

#### REAR

Replace the original pull rods with the HYPERPRO lowering pull rods. Put some pressure on the rear wheel before tightening the link.

WARNING! SHORTEN THE SIDE-STAND 25-30mm. AFTERMARKET REAR MUDGUARDS CAN NO LONGER BE USED.

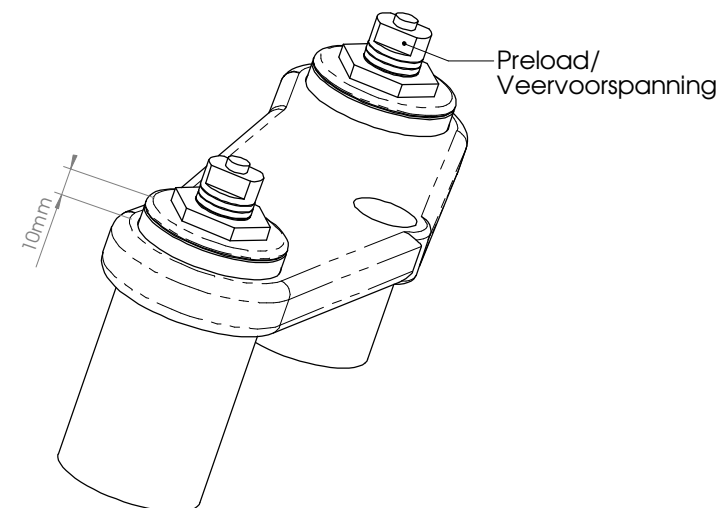

See [WWW.HYPERPRO.COM](http://WWW.HYPERPRO.COM) for more info about our products.