

# HYPERPRO

## LOWERING KIT / VERLAGINGSSET

for

### YAMAHA DT 125 R / X

'91-'98 (4BL), '99-'03 (DE03), '04-'05 (DE06)

#### LK-YA01-001-40 PART LIST

PR161150 - Pull rod/ trekstang	2
-	-
-	-
-	-

ALL IDEAS, DESIGNS, ARRANGEMENTS AND PLANS INDICATED OR REPRESENTED BY THIS DRAWING ARE OWNED BY HYPERPRO AND WERE CREATED, EVOLVED AND DEVELOPED FOR USE ON AND IN CONNECTION WITH THE SPECIFIC PROJECT. NONE SUCH IDEAS, DESIGNS, ARRANGEMENTS OR PLANS SHALL BE USED BY OR DISCLOSED TO ANY PERSON, FIRM OR CORPORATION FOR ANY PURPOSE WHATSOEVER WITHOUT THE WRITTEN PERMISSION OF HYPERPRO.

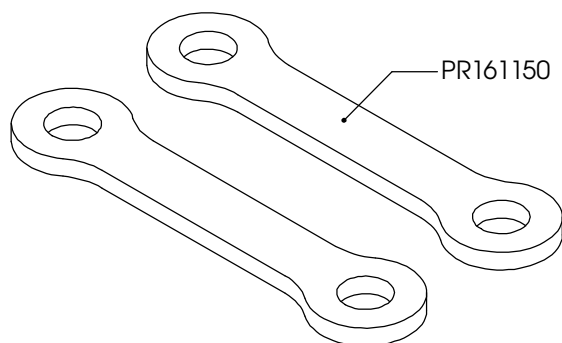

### Inbouw handleiding

#### VOORZIJDJE

De vorkpoten maximaal 30mm door de bovenste kroonplaat heen steken.

#### ACHTERZIJDJE

De bestaande link vervangen door de HYPERPRO verlagingslink.  
Het achterwiel eerst belasten voordat de link vastgezet wordt.

LET OP! DE LENGTE VAN DE ZIJSTANDAARD MOET  $\pm 30\text{mm}$  INGEKORT WORDEN.

### Instruction manual

#### FRONT

Mount the fork legs max 30mm through the triple clamp.

#### REAR

Replace the original link by the HYPERPRO lowering link.  
Put some pressure on the rear wheel before tightening the link.

WARNING! SHORTEN THE SIDE-STAND  $\pm 30\text{mm}$ .

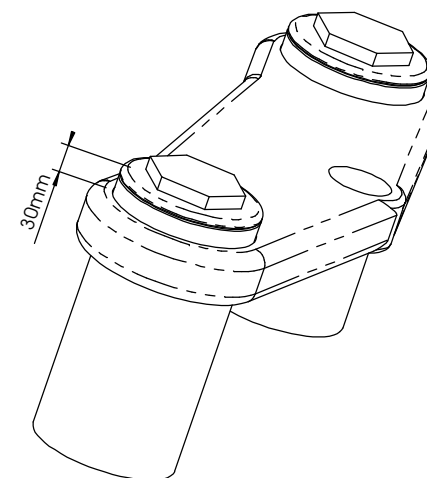

See [WWW.HYPERPRO.COM](http://WWW.HYPERPRO.COM) for more info about our products.