

HYPERPRO

STEERING DAMPER MOUNTING KIT

for

KTM 390 Duke Model 2017->

MK-KT03-S001 PART LIST

SD stroke 140 REVERSED	1	Washer M6 \varnothing 12	2
Damper Clamp [MP-DB0003]	1	Washer M6 \varnothing 17 h3	1
Fork Clamp [MP-FC0540]	1	Washer M8 \varnothing 16	1
Frame Bracket [MP-FRMK40]	1	Lock nut M6	1
Spacer [MP-SP081910]	2	O-Ring	1
M6x25 Low head	1	-	-
M8x25 Button head	1	-	-
M8x35 10.9	2	-	-

ALL IDEAS, DESIGNS ARRANGEMENTS AND PLANS INDICATED OR REPRESENTED BY THIS DRAWING ARE OWNED BY HYPERPRO AND WERE CREATED, EVOLVED AND DEVELOPED FOR USE ON AND IN CONNECTION WITH THE SPECIFIC PROJECT. NONE SUCH IDEAS, DESIGNS, ARRANGEMENTS OR PLANS SHALL BE USED BY OR DISCLOSED TO ANY PERSON, FIRM OR CORPORATION FOR ANY PURPOSE WHATSOEVER WITHOUT THE WRITTEN PERMISSION OF HYPERPRO.

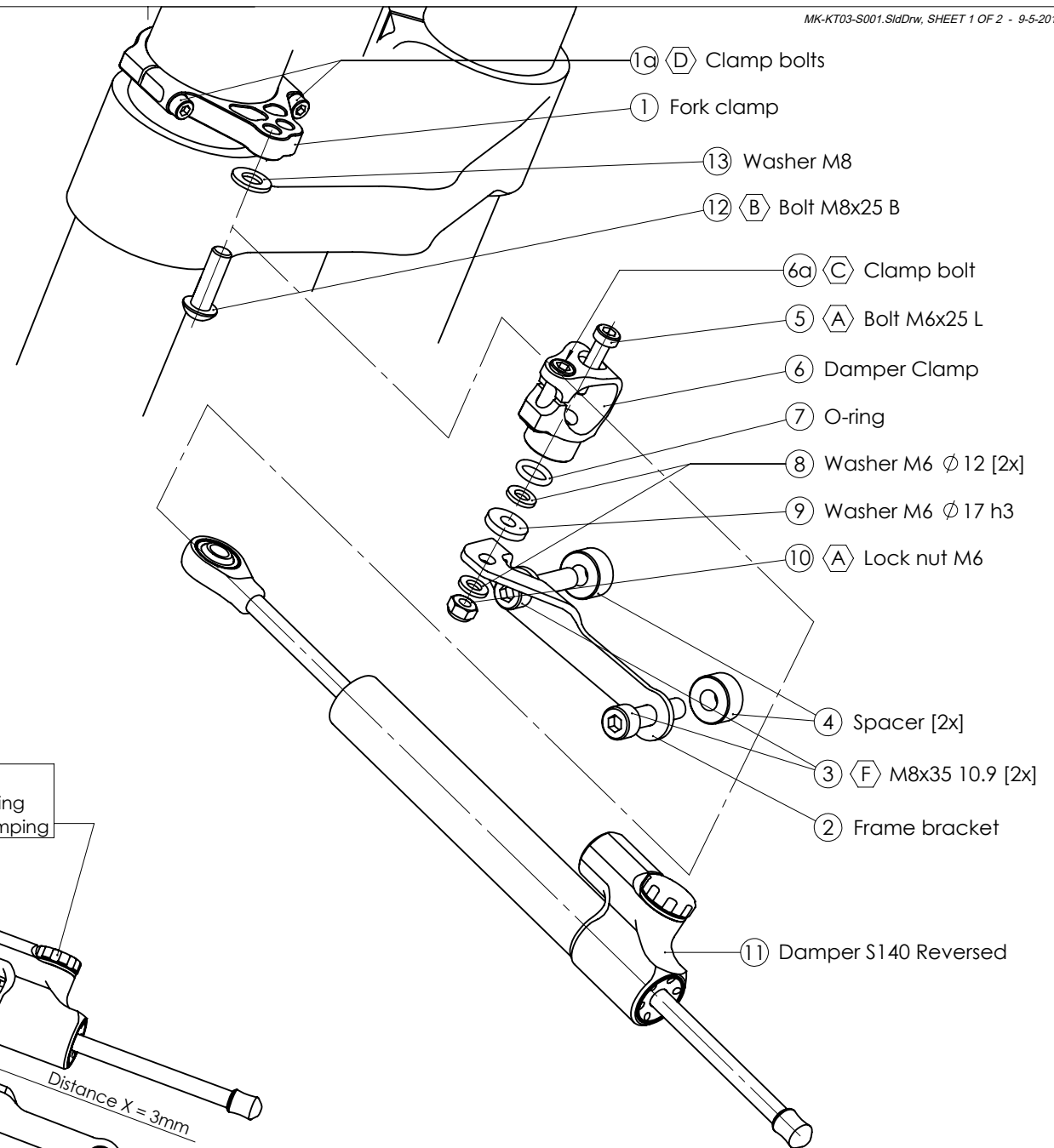
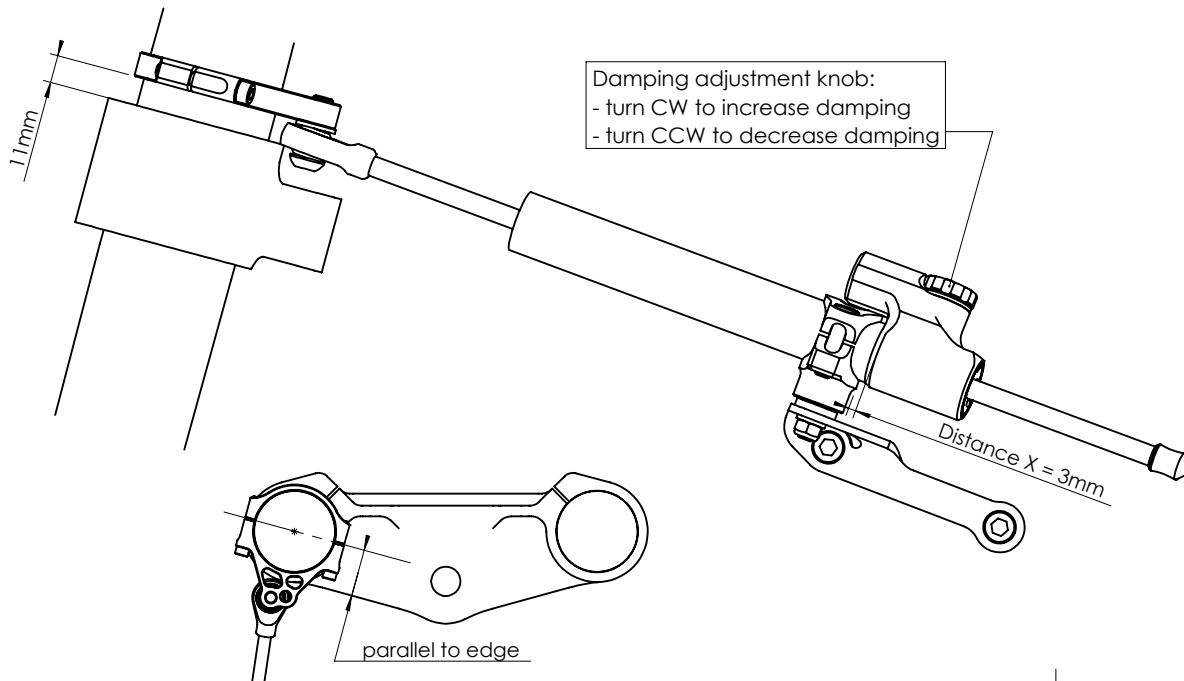

* TORQUES	
A: 5-9Nm / 44-80Lbs.In / 4.0-6.4Lbs.Ft	D: 8Nm / 70Lbs.In / 5.9Lbs.Ft
B: 14-17Nm / 124-150Lbs.In / 10.3-12.5Lbs.Ft	E: 55Nm / 486Lbs.In / 40Lbs.Ft
C: 6Nm / 53Lbs.In / 4.4Lbs.Ft	F: Factory torque (see owners manual)

HYPERPRO

STEERING DAMPER MOUNTING KIT

for

KTM 390 Duke Model 2017->

MK-KT03-S001 INSTALLATION INSTRUCTIONS

In general:

HYPERPRO can not be held responsible in any way for any form of physical, material, financial or other damage arising from use, assembly or overhaul of HYPERPRO products. HYPERPRO reserves the right to make changes without prior notice.

This product is ONLY TO BE INSTALLED BY A PROFESSIONAL MECHANIC.

This product is only to be used for the motorcycle brand, model and year stated specifically on top of the pages of this manual.

DO NOT attempt to install this product on motorcycles from any different brand, model and/or year than stated on the pages of this manual.

DO NOT use this kit for cars, boats, jet skis, snowmobiles, ATV's, aircraft, hovercrafts or any other vehicle and/or purpose.

HYPERPRO steering dampers are FOR RACE USE ONLY, NOT FOR HIGHWAY USE!

Before installation:

- Please read the entire manual carefully before starting the installation!
- Check if you have all the tools required. Good tools are a must.
- Protect your bike at the most important places in and around the work area (e.g. tank, fairing, frame, etc.), with a blanket, towel or similar.

During installation:

- Check all operations and parts carefully before, during and after performing each step.
- Clean all surfaces that are required for fitting parts together or for applying self adhesives or loctite, thoroughly with contact cleaner or another degreaser, unless otherwise stated.
- Be carefull not to damage or scratch any part of your bike.
- ALWAYS work relaxed and concentrated!! It is very easy to damage something or make a mistake.

After installation:

- Check and make sure that there is no contact between any part of the steering damper kit and any part of the motorcycle. The kit should not hit anything. Steering movement should not be limited by the steering damper. If the steering movement is limited, adjust the position of the tube in the clamp until steering movement is normal again. Do not forget to tighten the clamp bolt again!
- ALWAYS check the steering movement and feeling before each ride !
- FIRST RIDES: Start with the damper turned fully open (turn adjuster knob fully counter clockwise). Start adjusting in between rides with steps of MAX. 2 CLICKS (0.25 TURN) EACH TIME, until the damper is working satisfactory for your riding style.
- NEVER USE MAXIMUM SETTING, ALWAYS OPEN AT LEAST 2 CLICKS (0.25 TURN).
- WARNING ! DAMPER HAS AN ACTIVE / SPEEDSENSITIVE DAMPING SYSTEM;
 - Steering with NORMAL MOVEMENT should be FREE !!
 - Steering with FAST MOVEMENT should be CONTROLLED BY DAMPER !!
- HYPERPRO uses a special seal to reduce friction. The seal uses an oil film to work properly. It is normal that some oil can appear on the pistonrod.
- Damper works with oil: DAMPING CAN BE HARDER AT LOWER TEMPERATURES!

Step 1: install the fork clamp

Install the fork clamp using:

- Fork clamp (1)

Disassemble the fork clamp (1). Reassemble the clamp around the left fork leg as shown on page 1. Make sure the correct side is facing up. Set the height and angle as shown in the pictures and tighten the bolts (1a) lightly and evenly to a torque of approx. 8Nm/70Lbs.In/5.9Lbs.Ft.

Step 2: install the frame bracket

Install the frame bracket using:

- Frame bracket (2)
- 2x Bolt M8x35 10.9 (3)
- 2x Spacer (4)

Remove the 2 original bolts from the left engine mount and the lower frame tube. Install the frame bracket (2) using the supplied bolts (3) and spacers (4). Tighten the bolts to the factory torque specs (see your motorcycle's service manual).

Step 3: install the damper clamp

Install the damper clamp using:

- Bolt M6x25 Low head (5)
- Damper clamp (6)
- O-Ring (7)
- 2x Washer M6 ϕ 12 (8)
- Washer M6 ϕ 17 h3 (9)
- Lock nut M6 (10)

Install the damper clamp (6) as shown on page 1: use the M6 bolt (5), O-ring (7), washers (8 & 9) and M6 lock nut (10) in the correct order to mount the damper clamp (6) to the frame bracket (2). Tighten the bolt and nut to a torque of approx. 5-9Nm/44-80Lbs.In/4.0-6.4Lbs.Ft

Step 4: installing the steering damper

Install the steering damper using:

- Steering damper, stroke 140 reversed (11)
- Bolt M8x25 button head (12)
- Washer M8 ϕ 16 (13)

Ensure that the clamp bolt (6a) of the damper clamp is pointing out. Shove the damper (11), with the ball-joint first, through the clamp until the ball-joint can be fitted to the fork clamp (1). Use the washer (13) and M8 bolt (12) to mount the ball-joint to the correct hole in the fork clamp and tighten to a torque of approx. 14-17Nm/124-150Lbs.In/10.3-12.5Lbs.Ft. Position the damper tube until the distance "X" stated on page 1 is reached, set the angle of the adjuster body and tighten the M6 clamp bolt (6a) with a torque of approx. 6Nm/53Lbs.In/4.4Lbs.Ft.

Check if the damper is level horizontally and aligned to the bike. Check if the damper does not touch anything (e.g. tank) when steering from left to right. Check if the bike can make it's full steering angle from left to right. Adjust the position of the damper and/or the clamps if necessary to improve. Do not forget to re-tighten the bolts!